

The Type 52 Spherical Annular Blowout Preventer is designed for safe well pressure control during drilling and workover operations. The short, compact design has been proven and accepted for reliable operation in all oil and gas areas in the world. Five main components: lower housing, upper housing, piston, adapter ring, and packing element allow for easy maintenance and reliability. The packing element can close on all pipe, casing, wireline, coiled tubing and other objects to its full working pressure. Stripping of pipe, tubing, and wireline through the packing element can also be accomplished at lower pressures. The 52 Blowout Preventer can also perform open hole closure per the requirements of ISO 13533 (16A). Type 52 Blowout Preventers are shorter than most annular blowout preventers and are better suited where space is a priority.

The normal configuration of the 52 Blowout Preventer is of a flanged bottom (or clamp hub) connection and a studded top flange connection. Hydraulic operation is performed by connection to open and close (NPT) ports located on the body, which are connected to the control system. A spherical, steel reinforced rubber-packing element is forced inward by an upward movement of the piston. A spherical inverted bowl in the upper housing causes steel inserts in the packing element to rotate inward to the well bore. The steel inserts prevent extrusion of the rubber and feed inward to close on any pipe or tubular in the well bore. Replaceable bearings are used in the operating system to prevent metal contact of moving parts. An adapter ring located below the upper housing prevents contamination of the operating system during packing element replacement.

Replacement of the packing element is performed by removing nuts from stud bolting in the lower housing. The upper housing is then lifted upward. The packing element is then accessed for replacement. Wedged-cover upper housings are also available.

All materials used in the construction, except the upper housing bolting, of the Type 52 Spherical Blowout Preventer are rated by NACE MR-0175 and ISO 13533 for use in hydrogen sulfide environments.

### **SPECIAL FEATURES OF THE TYPE 52 SPHERICAL ANNULAR BLOWOUT PREVENTER:**

- Designed and manufactured to ISO 13533 and API Specification 16A for Drill Through Equipment
- Available in all standard bore and pressure ratings
- Shorter in height than comparative annular blowout preventers
- Replaceable bearings prevent metal contact of moving parts
- Adapter ring isolates control system during packer replacement
- Special rubber materials available for non standard environments
- Standard operation pressure of 1500 psi (10,34 Mpa)
- Forged materials rated for H<sub>2</sub>S service

# TYPE 52

## SPHERICAL BLOWOUT PREVENTER

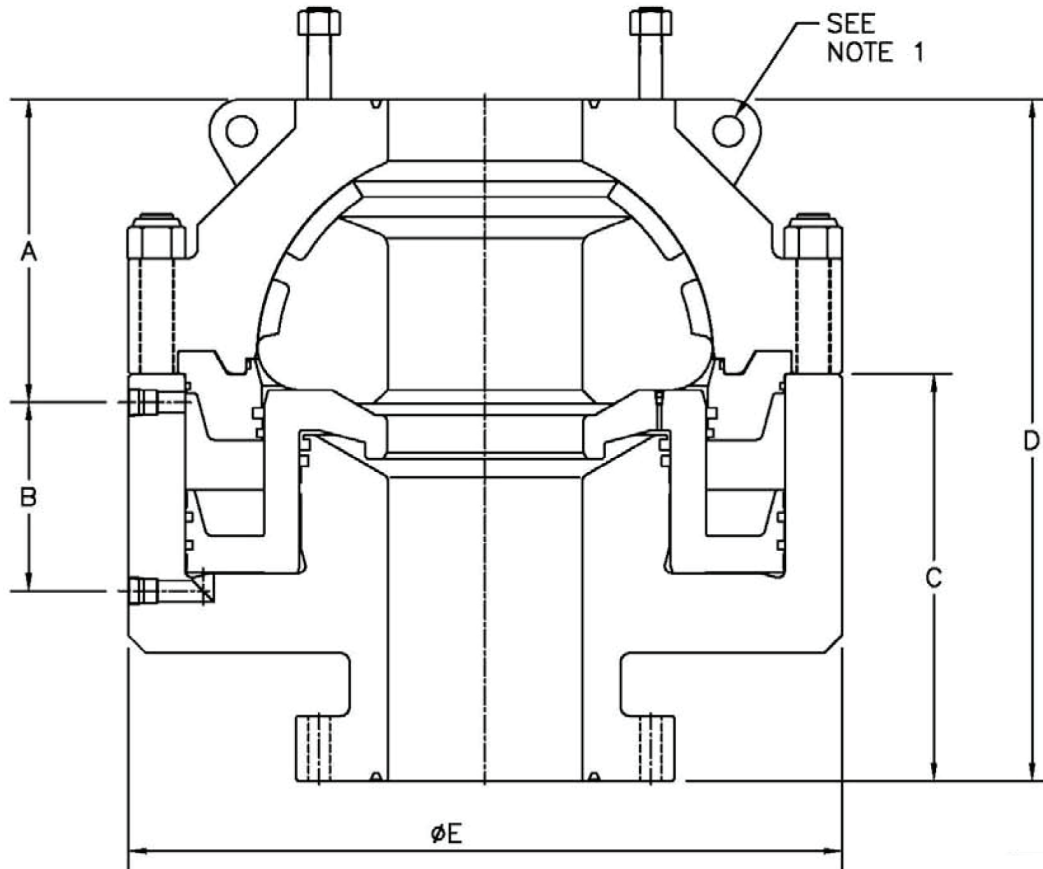

### ASSEMBLY DETAIL, TYPE 52 (SPHERICAL) BLOWOUT PREVENTER FLANGE BOTTOM X STUDDED TOP, BOLTED COVER

Size	Bottom Connection	A	B	C	D	E	F (lbs)	WT. (lbs)	HYD. PORTS	VOLUME (gal)	
										OPEN	CLOSE
7-1/16" 3M	7-1/16" 3M	13.75	8.75	16.62	29.12	29.00	4750	2925	1" NPT	3.43	4.92
7-1/16" 5M	7-1/16" 5M	13.75	8.75	18.36	30.88	29.00	13000	3175	1" NPT	3.21	4.57
7-1/16" 10M	7-1/16" 10M	19.31	11.13	25.31	42.68	43.00	50000	10600	1-1/4" NPT	13.95	17.20
7-1/16" 10M	7-1/16" 15M	19.31	11.13	26.19	43.25	43.00	50000	10675	1-1/4" NPT	13.95	17.20
11" 5M	11" 5M	17.69	12.62	25.56	41.50	44.75	34000	9550	1-1/4" NPT	14.60	18.70
11" 5M	11" 10M	17.69	12.62	26.68	42.62	44.75	34000	9800	1-1/4" NPT	14.60	18.70
13-5/8" 3M	13-5/8" 3M	19.68	10.88	22.56	40.74	46.38	34000	9100	1-1/2" NPT	14.67	23.50
13-5/8" 5M LW	13-5/8" 5M	19.56	12.38	24.25	42.25	46.50	50000	10000	1-1/2" NPT	14.67	23.50
13-5/8" 5M	13-5/8" 5M	20.67	12.00	26.31	44.98	50.00	50000	13650	1-1/2" NPT	17.41	23.58
13-5/8" 5M	13-5/8" 10M	20.62	12.00	30.38	49.12	50.00	50000	14200	1-1/2" NPT	17.41	23.58
20-3/4" 3M	20-3/4" 3M	21.41	14.16	38.31	48.44	54.12	50000	14600	1-1/2" NPT	26.90	43.40
21-1/4" 2M	21-1/4" 2M	21.06	8.00	28.12	46.25	49.00	50000	10850	1-1/2" NPT	16.92	32.59

**Notes:**

1. Upper body lift eyes, 2 places at 180°. Lift capacity "F" per lift eye.

# TYPE 52

## SPHERICAL BLOWOUT PREVENTER

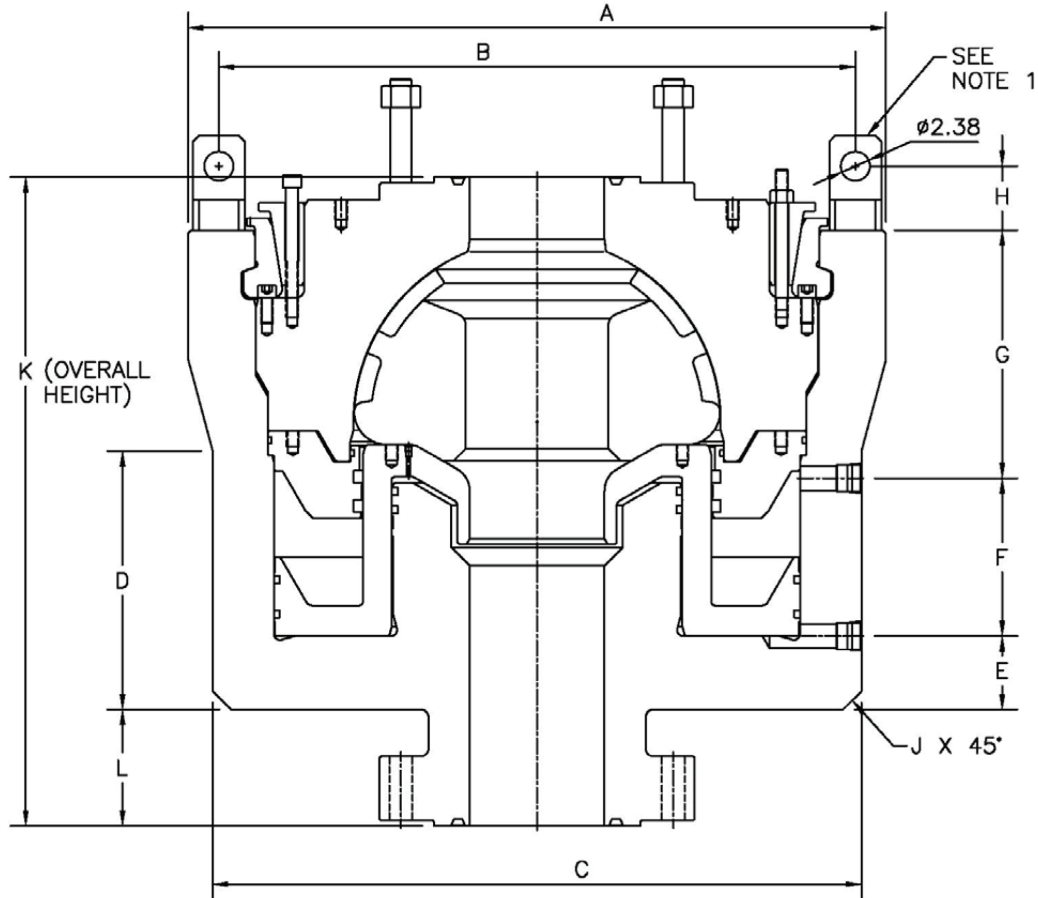

### ASSEMBLY DETAIL, TYPE 52 (SPHERICAL) BLOWOUT PREVENTER FLANGE BOTTOM X STUDDED TOP, WEDGE COVER

All dimensions in inches.

Size	Bottom Connection	A	B	C	D	E	F	G	H	J	K	L
11" 10M	11" 10M	57.00	52.00	53.00	21.12	6.00	12.88	20.25	5.25	1.50	53.00	9.50
13-5/8" 10M	13-5/8" 15M	64.50	58.57	59.00	23.00	7.00	14.56	21.94	5.25	2.00	61.75	13.75
16-3/4" 5M	16-3/4" 5M	60.00	55.56	56.75	23.68	6.75	14.12	15.88	5.25	1.75	52.31	9.25
18-3/4" 5M	18-3/4" 10M	66.25	61.75	64.62	28.96	7.00	18.87	18.38	5.25	2.00	62.63	13.63

Size	Weight (lbs)	Volume (gal)		Hyd. Conn.	
		Open	Close	No.	Size
11" 10M	23,000	24.67	30.58	2	2" NPT
13-5/8" 10M	32,475	32.64	40.16	4	2" NPT
16-3/4" 5M	22,900	25.61	33.26	2	2" NPT
18-3/4" 5M	36,100	37.61	48.16	4	2" NPT

**Notes:**

1. Upper body lift lugs, 4 places at 90°. Lift capacity 70,000 (31751 KG) /LUG.