

# *Church Energy*

**SERVICES LTD.**

## TYPE 50 (U) RAM BLOWOUT PREVENTER

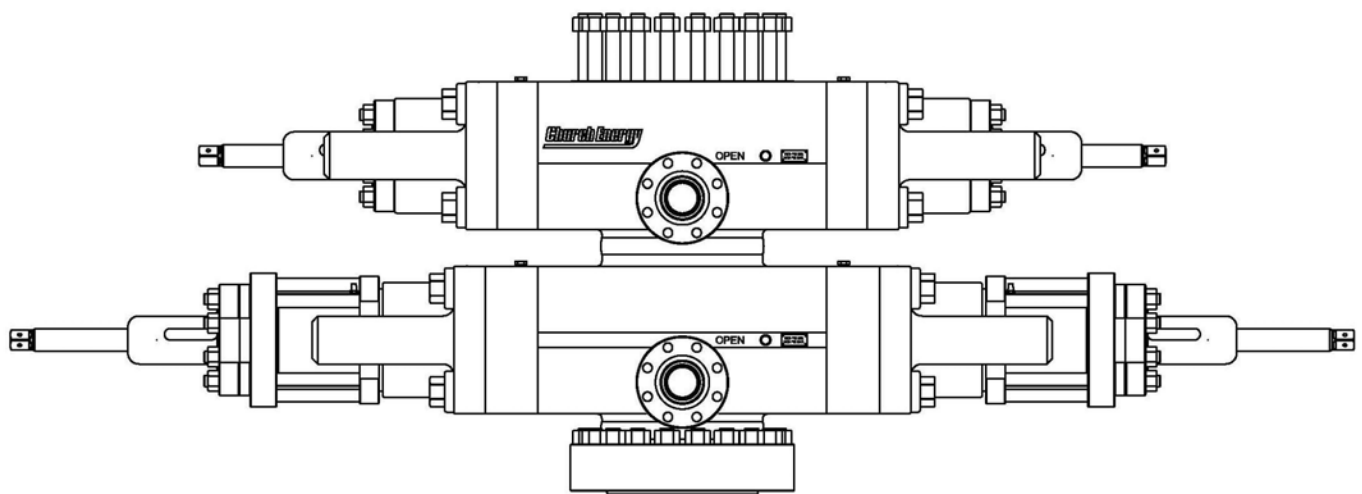

2810 WASHINGTON DR. \* HOUSTON, TEXAS \* 77038

# CHURCH ENERGY TYPE 50(U) RAM BLOWOUT PREVENTER

The Type 50 Blowout Preventer (BOP) is the most widely used blowout preventer in the world today. Its simple, compact design makes it well suited for subsea or surface drilling operations. The one-piece Type 50 Ram assembly provides a pressure-energized seal with maximum contact area to the drill pipe, casing, or tubing. This ensures a lower rubber pressure to the pipe and increased seal life. The oval ram and cavity design reduces stresses in the BOP body. Materials in contact with well fluids are resistant to hydrogen sulfide stress cracking per NACE Spec MR-0175.

The Type 50 BOP operating system is designed to provide a fast and reliable closure of the well bore. Sealing is energized by well pressure acting on the ram and is maintained even with a loss of BOP operating pressure. Manual locking screws are provided as standard and hydraulic wedge locking devices are available for added safety. The Type 50 BOP operating system also controls the opening of the BOP for removal of the Ram Block assemblies. After removal of four Bonnet Bolts from either side of the BOP body the application of closing pressure separates the Bonnets from the body and exposes the ram assemblies.

The well pressure is isolated from the operating system by a special combination of a resilient lip type seal, externally energized back up seal, and a vent port. This important feature ensures no leakage of the well fluids into the operating system.

Special consideration in the design of the Type 50 BOP operating control system has been made for increased life and reliability. All moving surfaces are hard chrome or hardfaced for prolonged wear and pitting resistance. Bearing materials are also used to prevent metal-to-metal contact during ram closure and ram change operations.

Church Energy Services only uses materials of the finest quality in the manufacture of the 50 BOP. Every component in the BOP is traceable back to its original mill test certificate.

## **Special design features of the Type 50 BOP:**

- Designed and manufactured to API Specification 16A and ISO 13533 for Drill Through Equipment
- Large bore shearing bonnets are available for shearing high strength pipe and casing
- All hydraulic connections to the BOP are 1" NPT
- Flanged or hub end connections with BX, AX, or CX type gaskets are available
- All BOP's are suitable for H<sub>2</sub>S service as standard per NACE MR0175
- A large variety of Ram assemblies are available:
  - Blind
  - Shearing/Blind
  - Pipe, casing, or tubing
  - Dual or Offset pipe
  - Centralizing pipe or Tubing
  - Variable Bore
  - Slip or hang-off

## TYPE 50 BOP OPERATING DATA AND FLUID REQUIREMENTS

BORE SIZE AND WORKING PRESSURE	7-1/16" 3000 TO 15000 PSI	11" 3000 TO 15000 PSI	11" 15000 PSI	13-5/8" 3000 TO 10000 PSI	13-5/8" 15000 PSI	16-3/4" 3000 TO 5000 PSI
Gallons To Open Pipe Rams (1 Set)	1.3	3.4	6.1	5.4	10.4	9.8
Gallons To Close Pipe Rams (1 Set)	1.3	3.5	6.2	5.8	10.6	10.6
Locking Screw Turns (Each End)	18	27	32	32	45	38
Closing Ratio	6.9:1	7.3:1	9.8:1	7.0:1	10.6:1	6.8:1
Opening Ratio	2.2:1	2.5:1	2.2:1	2.3:1	3.6:1	2.3:1

BORE SIZE AND WORKING PRESSURE	16-3/4" 10000 PSI	18-3/4" 10000 PSI	20-3/4" 3000 PSI TO 21-1/4" 2000 PSI	21-1/4" 5000 PSI	21-1/4" 10000 PSI	26-3/4" 3000 PSI
Gallons To Open Pipe Rams (1 Set)	11.6	21.2	7.9	27.2	24.5	10.1
Gallons To Close Pipe Rams (1 Set)	12.4	23.1	8.4	29.9	26.9	10.8
Locking Screw Turns (Each End)	45	54	46	54	51	58
Closing Ratio	6.8:1	7.4:1	7.0:1	6.2:1	7.2:1	7.0:1
Opening Ratio	2.3:1	3.7:1	1.3:1	4.0:1	4.0:1	1.0:1

## LARGE BORE SHEAR BONNET OPERATING DATA AND FLUID REQUIREMENTS

BORE SIZE AND WORKING PRESSURE	11" 3000 TO 10000 PSI	11" 15000 PSI	13-5/8" 3000 TO 10000 PSI	13-5/8" 15000 PSI	16-3/4" 3000 TO 5000 PSI	16-3/4" 10000 PSI	20-3/4" 3000 PSI TO 21-1/4" 2000 PSI
Gallons To Open Pipe Rams (1 Set)	7.4	8.9	10.5	16.0	18.1	18.2	14.3
Gallons To Close Pipe Rams (1 Set)	7.6	9.0	10.9	16.2	19.0	19.1	14.9
Locking Screw Turns (Each End)	27	32	32	45	38	45	46
Closing Ratio	12.0:1	15.2:1	10.8:1	16.2:1	10.4:1	10.4:1	10.8:1
Opening Ratio	4.8:1	3.7:1	4.5:1	6.0:1	4.4:1	4.4:1	1.7:1

# Church Energy

## SERVICES LTD.

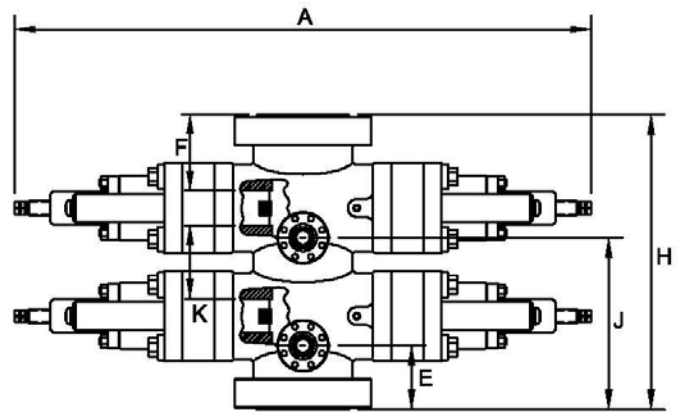
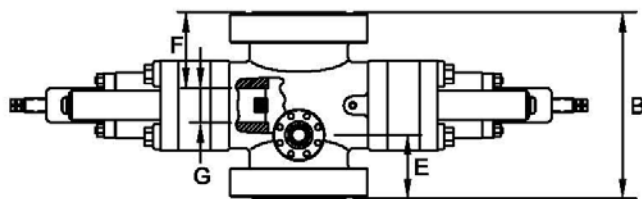
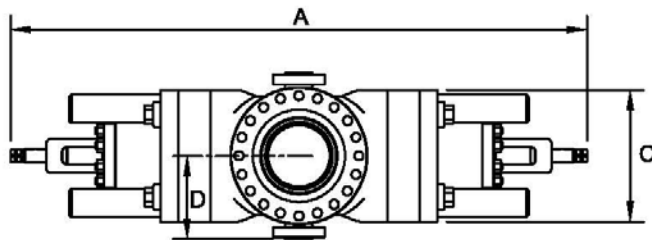

- A-1 Length, bonnets closed, locking screws in
- A-2 Length, bonnets open, locking screws out
- A-3 Length, bonnets closed, with wedgelocks
- A-4 Length, bonnets open, with wedgelocks
- B-1 Height, API flanged single
- B-2 Height, clamp hub single
- C Width, no side outlets
- D Centerline to outlet hub or flange (This dimension varies with outlet size per customer specification)

- E-1 Centerline of side outlet to bottom API flange
- E-2 Centerline of side outlet to bottom clamp hub
- F-1 Top of upper ram to top API flange
- F-2 Top of upper ram to top clamp hub
- G Height of ram
- H-1 Height, API flanged double
- H-2 Height, clamp hub double
- J-1 Centerline of upper side outlet to bottom flange
- J-2 Centerline of upper side outlet to bottom hub
- K Distance between rams

Size	Pressure Rating (psi)	Vertical Bore (in.)	A-1	A-2	A-3	A-4	B-1	B-2	C	E-1	E-2	F-1	F-2	G	H-1	H-2	J-1	J-2	K	Single Approx. Weight (lb.)	Double Approx. Weight (lb.)
7-1/16"	3000	7.06	74.00	109.50	-	-	24.06	-	20.25	8.75	-	7.84	-	5.50	41.00	-	25.69	-	11.44	2600	5000
7-1/16"	5000	7.06	74.00	109.50	-	-	27.50	25.19	20.25	10.41	9.25	9.82	8.47	5.50	44.19	41.88	27.09	25.84	11.19	2800	5200
7-1/16"	10000	7.06	74.00	109.50	-	-	30.56	25.19	20.82	11.06	9.38	12.03	10.34	5.50	48.82	45.25	29.12	27.44	12.56	3550	6400
7-1/16"	15000	7.06	74.00	109.50	-	-	31.81	-	20.82	11.69	-	12.66	-	5.50	49.88	-	29.75	-	12.56	3800	6750
11"	3000	11.00	96.25	146.88	-	-	29.06	-	20.12	9.81	-	10.53	-	6.75	49.25	-	30.00	-	13.44	5300	9900
11"	5000	11.00	96.25	146.88	110.12	150.19	34.31	29.31	25.12	12.44	9.94	13.16	10.66	6.75	54.50	49.50	32.62	31.12	13.44	5600	10200
11"	10000	11.00	96.25	146.88	110.12	150.19	35.69	32.19	25.75	13.12	11.38	13.84	12.09	6.75	55.88	52.38	33.31	31.56	13.44	6400	11300
11" Mod. 79	15000	11.00	124.00	175.31	124.50	167.12	44.81	33.88	32.00	16.69	11.22	17.78	12.31	9.25	69.75	58.81	41.62	36.16	15.69	10300	18400
13-5/8"	3000	13.62	112.12	171.50	122.69	166.06	31.31	-	29.25	10.31	-	11.53	-	7.50	53.38	-	32.38	-	14.56	7200	14300
13-5/8"	5000	13.62	112.12	171.50	122.69	166.06	33.81	31.94	29.25	11.56	10.62	12.78	11.84	7.50	55.88	54.00	33.62	32.69	14.56	7700	14800
13-5/8"	10000	13.62	114.12	172.75	124.69	167.31	41.69	32.81	30.25	15.12	10.69	17.09	12.66	7.50	66.62	57.75	40.06	35.62	17.44	10300	18400
13-5/8" Mod. B	15000	13.62	139.00	214.38	152.25	205.50	53.69	42.00	39.50	21.38	15.50	22.84	17.00	8.00	81.75	70.12	49.44	43.58	20.06	23700	43250
16-3/4" Mod. B	3000	16.75	127.25	204.56	147.25	199.38	40.06	31.75	35.75	13.31	9.16	15.41	11.25	9.25	65.88	57.56	39.12	34.97	16.56	13700	26650
16-3/4" Mod. B	5000	16.75	129.25	202.12	149.25	202.25	43.06	34.94	35.75	14.81	10.75	16.91	12.94	9.25	68.88	60.75	40.62	36.56	16.56	13750	26940
16-3/4"	10000	16.75	139.00	218.38	155.50	212.00	48.69	41.84	39.50	19.38	16.50	20.22	16.34	9.25	77.75	70.00	47.44	43.56	18.81	23300	43500
18-3/4"	10000	18.75	156.38	242.12	166.50	226.62	56.00	43.23	42.50	20.50	13.88	22.00	15.34	12.00	87.12	74.00	51.50	44.88	19.12	28900	56950
20-3/4"	3000	20.75	143.69	228.81	183.94	223.88	40.58	33.31	39.52	14.31	10.69	18.28	12.88	8.00	68.12	58.88	39.88	38.25	17.56	13650	25550
21-1/4"	2000	21.25	143.69	228.81	183.94	223.88	37.19	33.31	39.52	12.62	10.69	14.59	12.88	8.00	62.75	58.88	38.19	36.25	17.56	13250	25150
21-1/4"	5000	21.25	184.25	247.50	180.94	239.25	50.94	46.12	42.50	17.97	17.19	18.72	14.69	13.50	82.38	74.00	49.03	45.00	17.56	30000	58000
21-1/4"	10000	21.25	183.38	250.38	181.12	239.50	66.00	53.00	47.25	24.53	18.03	26.25	19.75	13.50	100.06	87.06	58.59	52.09	20.56	34850	65500
26-3/4"	3000	26.75	189.62	275.38	-	-	48.31	-	46.25	17.44	-	19.91	-	8.00	78.88	-	48.00	-	22.56	24000	44200

**Notes:**

1. All dimensions are in inches.
2. All BOP's conform to API Specification 16A.
3. Outlet sizes up to 4.06" bore (7.06" on 26-3/4" BOP) can be provided. They can be studded, clamp hub, or flanged per customer specifications.
4. Spacers between double BOP's can be provided for tool joint clearance.